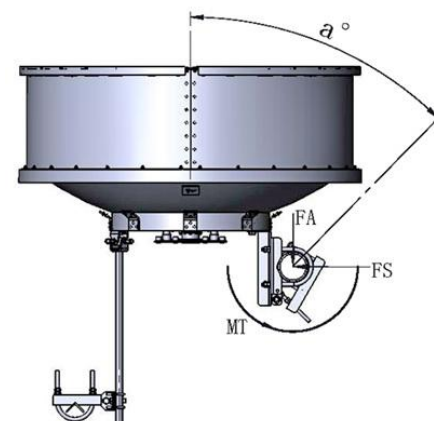

1.5m Ultra High Performance Antenna, Dual-Polarized, 10.125~11.7GHz
Electrical Specifications

Frequency (GHz)	10.125 ~ 11.7
Polarization	Dual (V and H)
Gain, Low (dBi)	41.1
Gain, Mid (dBi)	41.5
Gain, Top (dBi)	41.8
Beamwidth (deg)	1.2
Cross - pol. Discrimination_XPD (dB)	30
F/B Ratio (dB)	55
ISO. (dB)	30
VSWR (max)	1.3

Mechanical Specifications

Diameter (m)	1.5
Antenna Color	RAL9016
Flange Interface	UDR100 or Customized
Radome Options	High-strength Fabric
Azimuth Adjustment	Coarse : 360 ° Fine : ±15 °
Elevation Adjustment	Coarse : ±10 ° Fine : ±10 °
Diameter of Mounting Pole (mm)	Φ51~Φ114
Wind Velocity Survival Rating (km/h)	252
Wind Velocity Operational (km/h)	200
Ice-load (mm)	25.4
Operational Temperature (°C)	- 45~+60
Packaging	Wooden
L×W×H (mm)	1620x645x2150

Wind Load Specifications

Axial Force (FA) (N) @ survival wind speed	7170
Side Force (FS) (N) @ survival wind speed	2754
Twisting Moment (N•m) @ survival wind speed	3139

Dimension in mm

A	B	C	D
1560	278	1025	965
Note:			
1. The values of B and C are measured at the pole diameter of 114mm			
2. The thickness of the radome is not included in the dimensions of A and C			

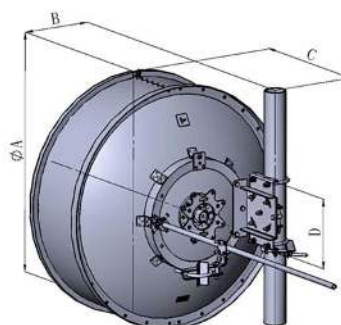
SANNY TELECOM EQUIPMENT CO., LTD

Address: Room 201 Building 1, Wanyang Industrial Park, No.82 Xiaotang Industrial Avenue, Shishan Town, Nanhai District, Foshan City 528223, Guangdong Province, China

Tel: +86 757 8766 0070

Fax: +86 757 8766 0500

Email: sales@sannytelecom.com

Website: www.sannytelecom.com